



NORMACONNECT® AccuSeal





High-performance clamp for joining two overlapping exhaust pipes

- ✓ Reaction block serves as a defined stop, avoiding pipe deformation
- ✓ 360° equal distribution of clamping force
- ✓ Durable installation without damaging the pipe ends

 Air Intake & Induction

 Exhaust Systems

 Cooling Systems

 Fuel & Oil Systems

 Turbocharger Installations

 Fixing & Retaining

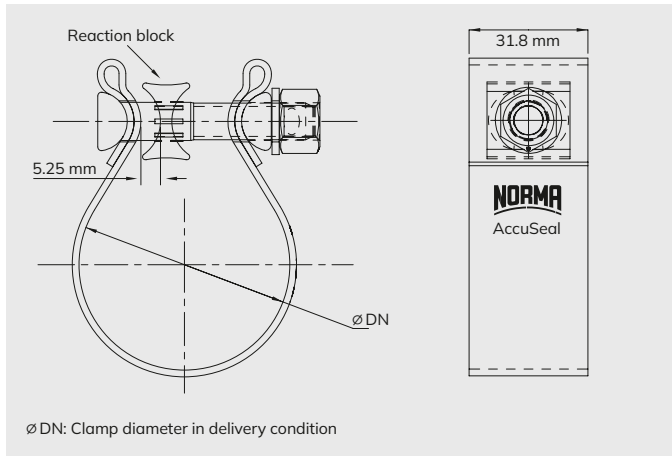

Applications

AccuSeal clamps are used to join two overlapping exhaust pipes in rear and center sections of passenger and commercial vehicles. Recommended for pipes with a wall thickness between 1.2 and 1.6 mm.

Materials

Group	W1, W3, W4
--------------	------------

Part Number	Description	Clamp Diameter in Delivery Condition (Ø DN in mm)	Material	Packaging Quantity (pcs)
0366 6100 564	AccuSeal 564	56.40	W1	50
0366 6100 629	AccuSeal 629	62.90	W1	50
0366 6100 656	AccuSeal 656	65.60	W1	50
0366 6100 689	AccuSeal 689	68.90	W1	50
0366 6110 706	AccuSeal 706	70.60	W1	50
0366 6100 949	AccuSeal 949	94.90	W1	50
0366 6121 072	AccuSeal 1072	107.20	W1	50
0366 6101 582	AccuSeal 1582	158.20	W1	25
0366 6100 476	AccuSeal 476	47.60	W3	50
0366 6100 506	AccuSeal 506	50.60	W3	50
0366 6100 520	AccuSeal 520	52.00	W3	50
0366 6100 549	AccuSeal 549	54.90	W3	50
0366 6110 564	AccuSeal 564	56.40	W3	50
0366 6110 606	AccuSeal 606	60.60	W3	50
0366 6120 629	AccuSeal 629	62.90	W3	50
0366 6110 649	AccuSeal 649	64.90	W3	50
0366 6110 656	AccuSeal 656	65.60	W3	50
0366 6100 691	AccuSeal 691	69.10	W3	50
0366 6120 706	AccuSeal 706	70.60	W3	50
0366 6000 756	AccuSeal 756	75.60	W3	50
0366 6120 818	AccuSeal 818	81.80	W3	50
0366 6110 949	AccuSeal 949	94.90	W3	50
0366 6111 072	AccuSeal 1072	107.20	W3	50
0366 6101 326	AccuSeal 1326	132.60	W3	50
0366 6111 582	AccuSeal 1582	158.20	W3	50
0366 6120 506	AccuSeal 506	50.60	W4	50
0366 6120 556	AccuSeal 556	55.60	W4	50
0366 6120 606	AccuSeal 606	60.60	W4	50
0366 6110 626	AccuSeal 626	62.60	W4	50
0366 6120 656	AccuSeal 656	65.60	W4	50
0366 6130 706	AccuSeal 706	70.60	W4	50
0366 6100 756	AccuSeal 756	75.60	W4	50
0366 6100 816	AccuSeal 816	81.60	W4	50
0366 6001 327	AccuSeal 1327	132.70	W4	50

Looking for the right AccuSeal? Contact us!

For best leakage performance choose the right AccuSeal. Selecting the correct AccuSeal depends on various parameters, including diameter, thickness and material of both male and female exhaust pipes. Please contact the NORMA Sales Team or the sales representative of your distributor with the above details (Figure 3) to select the right AccuSeal clamp for your application.

EXHAUST CLAMPS & COUPLINGS

Figure 1 SealSlot design

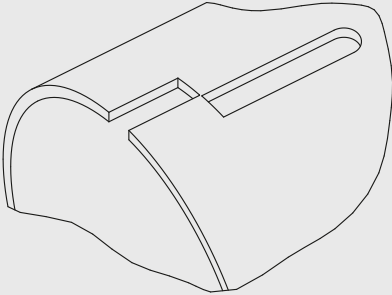
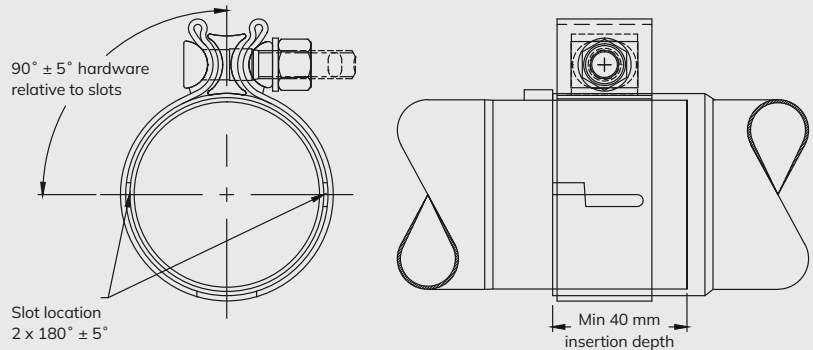

Figure 2 Example of exhaust pipes – AccuSeal assembly configuration



Notes

- ✓ For optimal sealing performance, the AccuSeal clamp should be used with SealSlot design (Figure 1). Please contact us for details of the SealSlot design.
- ✓ Use a two-slot system for best leakage performance. We recommend two symmetrical slots oriented at 90° on either side from the center of the reaction block (Figure 2).
- ✓ For good leakage performance of the AccuSeal joint, use a minimum insertion depth of 40 mm (Figure 2).

Figure 3 Required information to select the right AccuSeal clamp

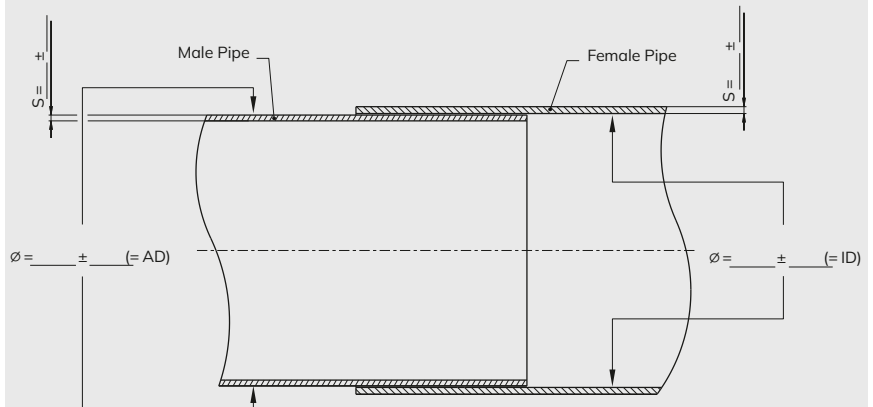

Additional benefits

- ✓ Exhaust connections are serviceable and easy to disassemble
- ✓ Clamp available in different materials to cover a broad range of exhaust pipes
- ✓ Low weight and low leakage rate

NORMACONNECT® AccuSeal is part of a broad portfolio. Discover more!



NORMACONNECT® SEC



NORMACONNECT® EuroCoupler

PREMIER TecDoc® DATA SUPPLIER



Do you have questions or require a personal consultation?

Feel free to contact our Automotive Aftermarket Team!

Visit our website for more information about our Automotive Aftermarket products: norma-aftermarket.com

