

NORMACLAMP® CV Boot Clamp

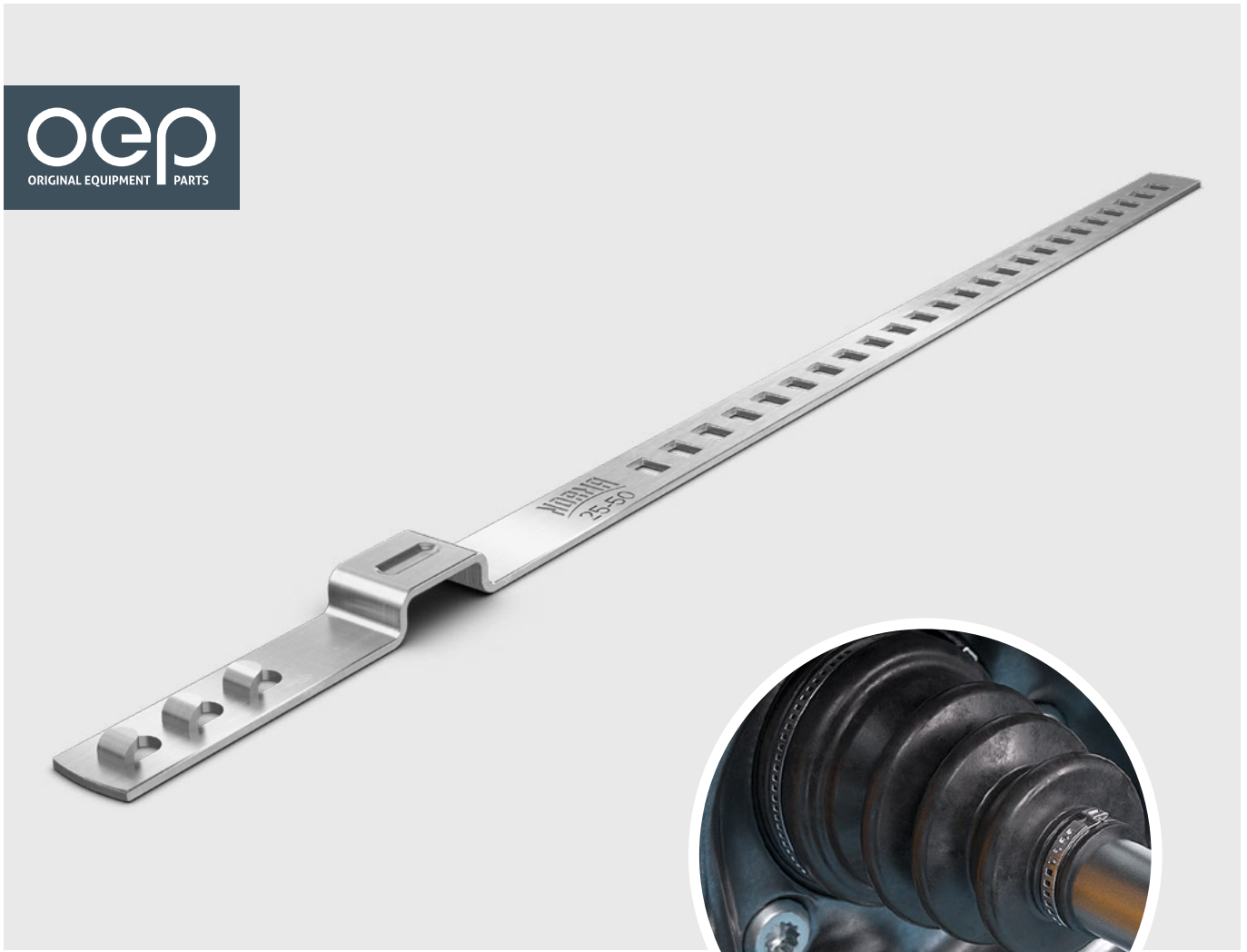

Only two clamps cover a clamping range of 25–120 mm

- ✓ Three-tooth locking mechanism for higher clamping force
- ✓ Flexibility to mount different sizes of rubber boots
- ✓ Can be used in passenger and commercial vehicle

Air Intake & Induction	Exhaust Systems
Cooling Systems	Fuel & Oil Systems
Turbocharger Installations	Fixing & Retaining

NORMACLAMP® CV Boot Clamp

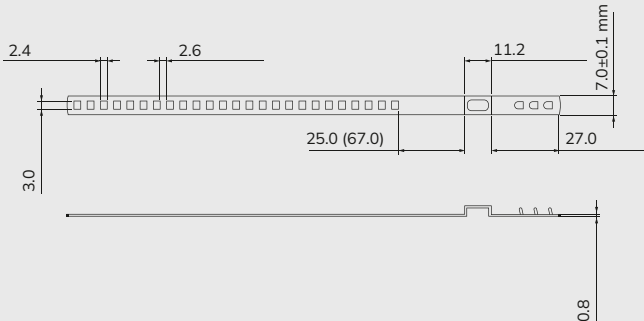

Applications

CV Boot Clamp is used to mount various sizes of rubber boots on drive shafts.

Material

Group W4 (AISI 304)

Part Number	Description	Clamping Range (mm)	Packaging Quantity (pcs)
0110 7016 050	CV Boot Clamp 25-50	25-50	100 (100 pcs x 1)
0110 7016 120	CV Boot Clamp 40-120	40-120	100 (100 pcs x 1)

More benefits

- ✓ W4 (AISI 304) material to ensure high resistance to corrosion
- ✓ Perfect all-round seal

NORMACLAMP® CV Boot Clamp is part of a broad portfolio. Discover more!



NORMAFIX® RSGU



NORMAFIX® Stainless Steel CableTie



Do you have questions or require a personal consultation?

Feel free to contact our Automotive Aftermarket Team!

Visit our website for more information about our Automotive Aftermarket products: norma-aftermarket.com

